

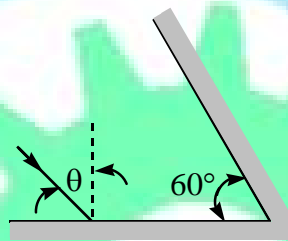

RAY OPTICS PART-I REFLECTION
PART-A LEVEL-I (THEORY)

SINGLE ANSWER CORRECT

1. A ray of light strikes one of two mirrors that meet at a 60° angle as shown in Fig. As the angle of incidence θ is increased the angle between the final reflected ray and the incident ray



- A) Increase B) decreases C) remains the same
D) The question cannot be answered without solving each incident angle individually
2. A ray of light shines into two mirrors that meet at an angle α (measured in radians). What is a reasonable estimate of the maximum number of times the light will bounce off of the mirrors before it comes back out?

- A) $2\pi / \alpha$ B) π / α C) $\sqrt{\pi / \alpha}$ D) $\sqrt{\alpha / \pi}$

3. An arrow object is viewed through a bent metal tube with the help of four plane mirrors A, B, C and D as shown in the figure. Every mirror is inclined at an angle of 45° with the horizontal. Which of the following represents correct images made by these mirrors in sequence?

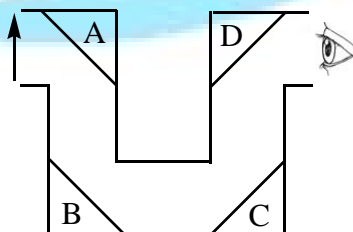

- A) $\uparrow \leftarrow \rightarrow \uparrow$ B) $\leftarrow \uparrow \rightarrow \uparrow$
C) $\rightarrow \downarrow \leftarrow \uparrow$ D) $\uparrow \downarrow \uparrow \downarrow$

4. A mirror produces a real image at i from a real object at $0 > i$. What can you conclude about the focal length of the mirror?
- A) $f < 0$ B) $0 < f < i$ C) $i < f < 0$ D) $0 < f$
5. No matter how far you stand from a certain mirror, your image appears upright. What type of mirror is this ?
- A) Concave B) Convex C) Plane D) Either (B) or (C)
- E) There is no enough information to answer this question
6. While standing in front of a certain mirror, you notice that your image appears enlarged. What type of mirror is this ?
- A) Concave B) Convex C) Plane D) Either (A) or (B)
- E) There is no enough information to answer this question
7. It is a common belief that reading in reasonably bright light is more comfortable than reading in dim light. Which of the following is the most appropriate reason for this effect ?
- A) Contraction of ciliary muscles reduces astigmatism
- B) Contraction of pupil in bright light reduces spherical aberration
- C) In bright light image formed on retina has more intensity than that in dim light
- D) This is purely a psychological effect; bright light merely stimulates some more visual neurons that are normally dormant
8. The passenger side-view mirror on an automobile often has the notation "Objects in mirror are closer than they appear". Is the image really farther away than the object?
- A) Yes, the image is smaller and farther away than the object
- B) No, the image is smaller and closer than the object
- C) No, the image is larger and closer than the object
- D) Yes, the image is larger and farther away than the object
9. A light ray travelling parallel to the principal axis of a concave mirror strikes the mirror at angle of incidence θ . If radius of curvature of the mirror is R , then after reflection, the ray meets the principal axis at distance d from the centre of curvature, then d is :
- A) $\frac{R}{2}$ B) $R\left(1 - \frac{1}{2\cos\theta}\right)$ C) $\frac{R}{2\cos\theta}$ D) $\frac{R}{2}(1 + \cos\theta)$

10. A small square object is placed between centre of curvature and focus of concave mirror as shown in figure. What will be the correct shape of image ?

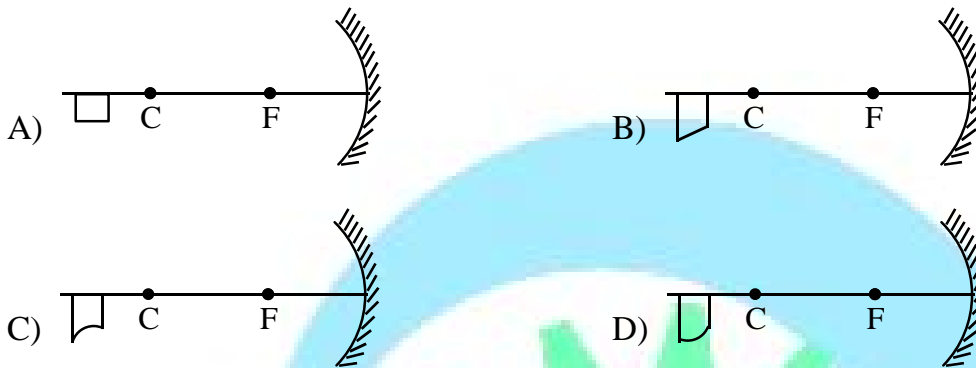
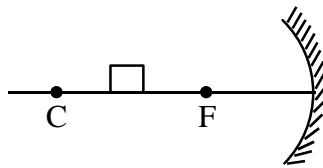

11. A converging beam of light having angle of convergence 4° is incident upon a convex mirror as shown. Find the angle of convergence after reflection. Focal length of mirror is 10 cm.

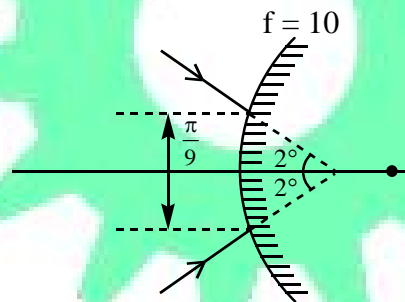

- A) 0.5° B) 1° C) 1.5° D) 2°
12. A spherical mirror is polished on both sides. When the convex side is used as a mirror the image is erect with magnification $\frac{1}{4}$. What is the magnification when the concave side is used as a mirror, the object remaining the same distance from the mirror ?

- A) $-\frac{1}{4}$ B) $-\frac{1}{2}$ C) $-\frac{1}{3}$ D) $+\frac{1}{4}$

13. A parabolic mirror is silvered at inner surface. The equation of the curve formed by its intersection with X-Y plane is given by $y = \frac{x^2}{4}$. A ray travelling in X-Y plane along line $y = x + 3$ hits the mirror in second quadrant and gets reflected ray will be :

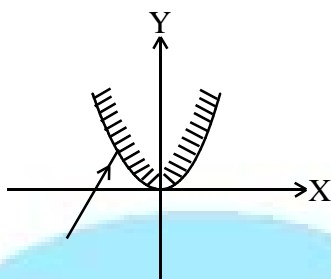

- A) $\frac{1}{\sqrt{2}}(-\hat{i} - \hat{j})$ B) $\frac{1}{\sqrt{2}}(\hat{i} + \hat{j})$ C) $\frac{-2\hat{i} - 3\hat{j}}{\sqrt{13}}$ D) $\frac{2\hat{i}}{\sqrt{3}} - \frac{(2\hat{i} + \hat{j})}{\sqrt{5}}$
14. Ram is looking at his face in a mirror kept 10 cm away and he finds that his image is erect and magnified ($m = 1.8$). If he holds the mirror 50 cm away :
- A) He cannot see the image because reflected rays falling on his eyes are converging
 B) He sees a magnified and erect image
 C) He sees a diminished and inverted image
 D) He sees a magnified and inverted image

ONE OR MORE THAN ONE ANSWER CORRECT

15. Let A and B be the detectors used to view the image of O in the mirror. If surface of the mirror is polished to reduce roughness, brightness of image detected by

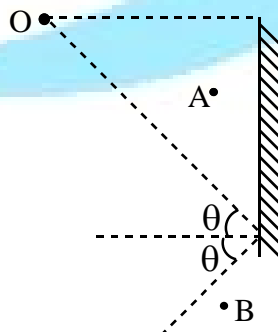

- A) A increases B) A decreases C) B increases D) B decreases

16. I is the image of a point object O formed by spherical mirror. Then which of the following statement(s) is/are **CORRECT** ?
- A) If O and I are on same side of the principal axis, then they have to be on opposite side of the mirror
- B) If O and I are on opposite sides of the principal axis then they have to be one same side of the mirror
- C) If O and I are on opposite side of the principal axis, then they can be on opposite side of the mirror as well
- D) If O and I are on same side of the principal axis, then they have to be one same side of the mirror
17. The angle between two flat mirrors is changed by rotating one of the mirrors around the edge of another with a constant angular velocity $\omega = 1.5 \text{ deg/sec}$. Source of light S is placed as shown in the figure at a distance $h = 10 \text{ cm}$. At the initial moment mirrors were in the same plane ($\phi = 180^\circ$). After what minimum time (in second), 3 images will be formed by the mirrors.

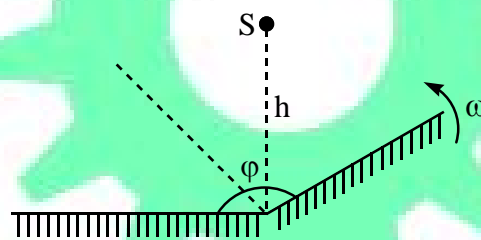

- A) 20 B) 30 C) 40 D) 60
18. For a concave mirror, graph of square of magnification and image distance from pole is given for real object. Choose the **CORRECT** statement(s).

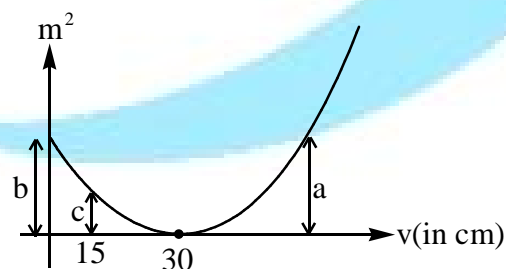

- A) This graph is hyperbola
- B) length a must be equal to length b
- C) radius of concave mirror is 60 cm
- D) the length c will be half of length a

19. A spherical mirror forms image of a real object as shown, choose the **CORRECT** option(s) :

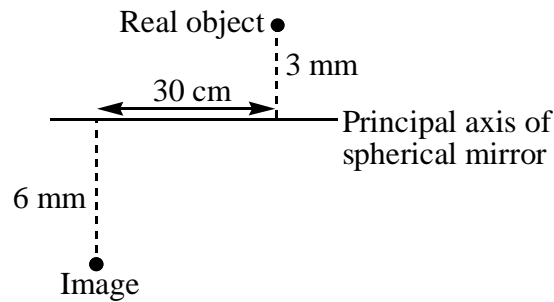

- A) Mirror is concave of radius 40 cm
 B) Mirror of convex of radius 40 cm
 C) Mirror is 30 cm from object along principal axis
 D) Mirror is 60 cm from image along principal axis
20. A concave spherical mirror has a radius of curvature of 50 cm. Find two positions of an object for which the image is four times as large as the object.
- A) $\frac{75}{4}$ cm from mirror
 B) 125 cm from mirror
 C) $\frac{125}{4}$ cm from mirror
 D) 32 cm from mirror
21. Consider mercury (Hg) rotating about a vertical axis with uniform angular velocity ω filled in a cylindrical container. The liquid surface is curved. The figure shows a cross sectional view of the curved surface.

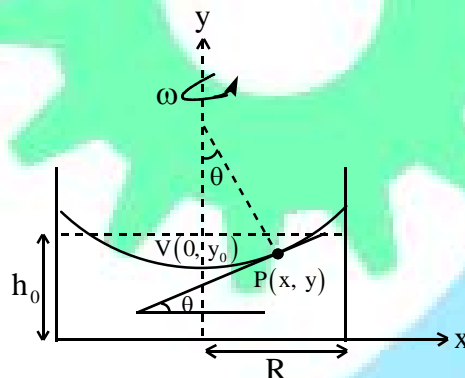

Ignore surface tension and viscosity. Mark the **CORRECT** statement(s) :

[**Hint** : coordinates of focus for parabola $x^2 = 4ay$ is given by $(0, a)$]

- A) Steady state angle θ made by tangent to the surface at $P(x, y)$ with the horizontal is given

by $\tan^{-1}\left(\frac{\omega^2 x}{g}\right)$

- B) Steady state angle θ made by tangent to the surface at $P(x, y)$ with the horizontal is given

by $\sin^{-1}\left(\frac{\omega^2 x}{g}\right)$

- C) If the focal length of the mirror formed by shiny liquid surface is 20 cm then ω is 5 rad/s
 D) If the focal length of the mirror formed by shiny liquid surface is 20 cm then ω is 10 rad/s

22. The diagram below shows an object located at point P, 0.25 meter from a concave spherical mirror with principal focus F. The focal length of the mirror is 0.10 meter.

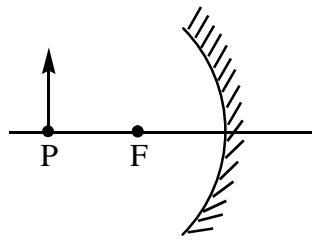

How does the image change as the object is moved from point P toward point F ?

- A) Its distance from the mirror decreases
 - B) The size of image decreases
 - C) Its distance from the mirror increases
 - D) The size of images increases
23. You are required to design a little dentist's mirror to be fixed at the end a shaft at the end a shaft for use in someone's mouth. The image should be erect and when held at 1.5 cm from a tooth, it should produce an image twice the size of the tooth.
- A) The mirror is convex with $|f| = 3\text{ cm}$
 - B) The mirror is concave with $|f| = 3\text{ cm}$
 - C) The image of this tooth is 3 cm behind the mirror
 - D) The image of this tooth is 3 cm in front of the mirror

COMPREHENSION-1

Sign convention is taken as +ve direction in the direction of light ray and the graph is drawn between $\frac{1}{u}$ and v for a spherical mirror.

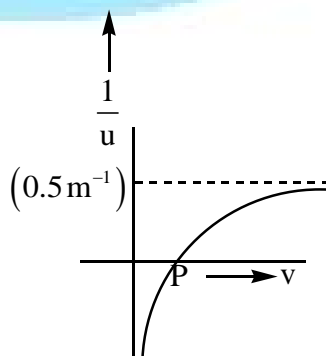

24. What is the focal length of the mirror ?
 A) -50cm B) -200cm C) $+200\text{cm}$ D) $+50\text{cm}$
25. The coordinates of point P are :
 A) $(50\text{cm}, 0\text{cm})$ B) $(100\text{cm}, 0\text{cm})$ C) $(200\text{cm}, 0\text{cm})$ D) data insufficient
26. Magnitude of slope of curve at point P :
 A) 1m^{-2} B) 0.25m^{-2} C) 2m^{-2} D) data insufficient

COMPREHENSION-2

Two concave mirrors with equal focal length f , is placed one above other at a separation of d . upper mirror has a small hole at its centre as given. A small object placed at centre of lower mirror. Take first reflection at above mirror and second at lower and answer the given questions for these two reflections only.

For final image to be at the hole of the upper mirror.

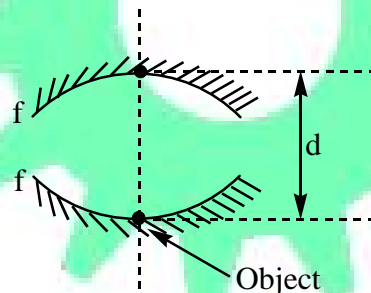

27. Value of d for given possibility :
 A) f B) $2f$ C) $3f$ D) $\frac{f}{3}$
28. Nature of image :
 A) erect with equal size B) erect with unequal size
 C) inverted with equal size D) inverted with unequal size

MATCHING

29. Considering the possibility of object – image combination match the column :

	Column – I		Column – II
(a)	Real object almost touching the mirror, virtual and erect image of magnification almost 1	(p)	Plane mirror
(b)	Virtual image for a virtual object	(q)	Concave mirror
(c)	Real image for a real object	(r)	Convex mirror
(d)	Virtual image for a real object	(s)	None of the above

30. In column – I possible instantaneous velocity vector of the image with respect to ground are shown. The corresponding velocity vectors of images are the situations shown in column – II. Match column – I with the column – II.

	Column – I		Column – II
(a)		(p)	
(b)		(q)	
(c)		(r)	
(d)		(s)	
		(t)	None of these

31. In column – I different situations are given and in column – II, nature of image is given. Match the entries of column – I with column – II.

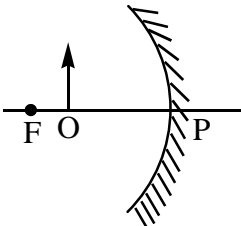
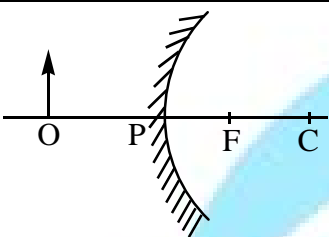
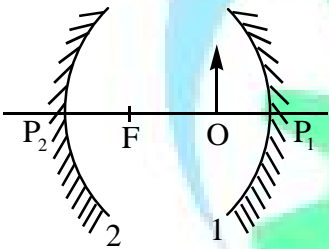
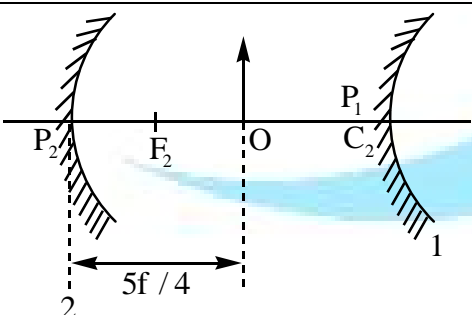
	Column – I		Column – II
(a)	 <p>Object lies between Pole and Focus of a concave mirror</p>	(p)	Image is real
(b)	 <p>Object is kept in front of convex mirror</p>	(q)	Image is enlarged
(c)	 <p>Object is kept between two similar concave mirrors. Object is kept between pole and focus of concave mirror-1 and concave mirror-2 is kept at center of curvature of concave mirror-1. Consider the image formed after two reflection, first reflection from concave mirror-2 and second from mirror-1.</p>	(r)	Image is inverted
(d)	 <p>Object is kept between convex mirror-1 and concave mirror-2 having same radius of curvature. f is the focal length of convex mirror. Consider the image after two reflection, first reflection from mirror-2 and second from mirror-1. C_2 is the centre of curvature of mirror-2.</p>	(s)	Image is diminished
		(t)	Image is virtual

32. An extended object is moving in front of concave mirror as shown in figure. On L.H.S various velocity of object and position is given. On R.H.S some properties of image and its velocity is given. Consider velocity along x-axis only.

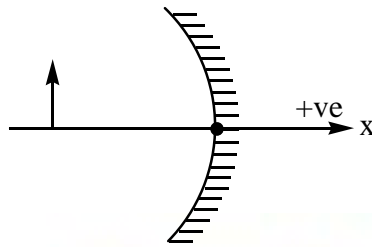

	Column – I		Column – II
(a)	+ve velocity and object is between focus and centre of curvature	(p)	+ve velocity
(b)	-ve velocity and object is between focus and pole	(q)	-ve velocity
(c)	-ve velocity and object is beyond centre of curvature	(r)	Size of image is increasing
(d)	-ve velocity and object is virtual	(s)	Size of image is decreasing

INTEGER

33. The mirrors labelled L_1 or left mirror and L_2 for right mirror in the figure are parallel to each other and 3.0 m apart. A person standing 1.0 m from the right mirror (L_2) looks into this mirror and sees a series of images. The third nearest image seen in the right mirror is situated at a distance of $8n$ metres from the person. Find n ?

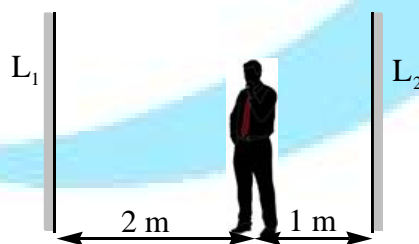

34. A cube of side length 1 mm is placed on the axis of a concave mirror at a distance of 45 cm from the pole. One edge of the cube is parallel to the axis. The focal length of the mirror is 30 cm. Find approximate volume of the image.

PART-B LEVEL-II (APPLICATIONS)

SINGLE ANSWER CORRECT

1. Two plane mirrors AB and AC are inclined at an angle $\theta = 20^\circ$. A ray of light starting from point P is incident at point Q on the mirror AB, then at R on mirror AC and again on S on AB finally the ray ST goes parallel to mirror AC. The angle which the ray makes with the normal at point Q on mirror AB is

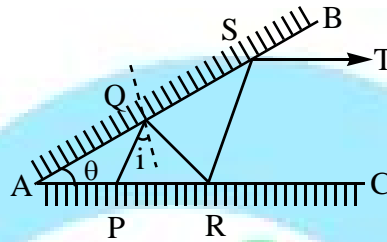

- (A) 20° (B*) 30° (C) 40° (D) 60°
2. A point source of light S is placed in front of two large mirrors as shown. Which of the following observers will see only one image of S?

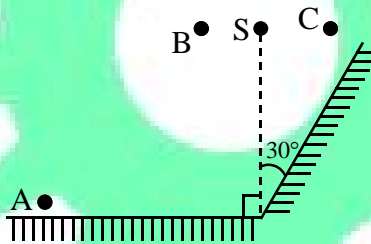

- (A) only A (B*) only C (C) Both A and C (D) Both B and C
3. A point object is between the Pole and Focus of a concave mirror, and moving away from the mirror with a constant speed. Then, the velocity of the image is :
- A) away from mirror and increasing in magnitude
B) towards mirror and increasing in magnitude
C) away from mirror and decreasing in magnitude
D) towards mirror and decreasing in magnitude

4. A concave mirror is placed on a horizontal table, with its axis directed vertically upwards. Let O be the pole of the mirror and C its centre of curvature. A point object is placed at C. It has a real image, also located at C (a condition called auto-collimation). If the mirror is now filled with water, the image will be:

- A) real, and will remain at C
- B) real, and located at a point between C and ∞
- C) virtual, and located at a point between C and O.
- D) real, and located at a point between C and O.

5. A point object is placed at a distance of $\frac{100}{3} \text{ cm}$ on principal axis of a concave mirror of radius of curvature 40cm. The mirror starts rotating about its pole at an angular velocity of $\omega = 2 \text{ rad/s}$. What is the speed and direction of motion of the image at the given instant

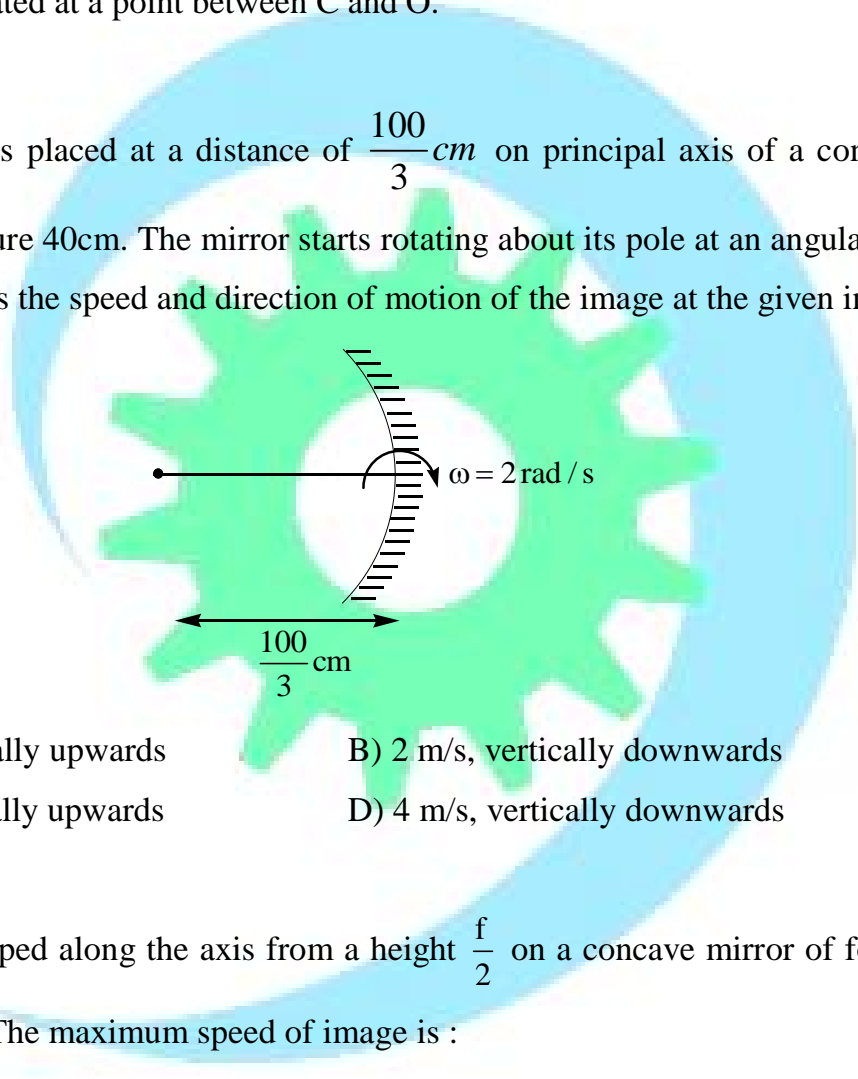

- A) 4 m/s, vertically upwards
- B) 2 m/s, vertically downwards
- C) 2 m/s, vertically upwards
- D) 4 m/s, vertically downwards

6. A particle is dropped along the axis from a height $\frac{f}{2}$ on a concave mirror of focal length f as shown in figure. The maximum speed of image is :

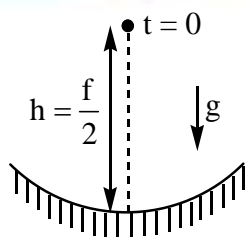

- A) ∞
- B) $\frac{3}{4} \sqrt{3fg}$
- C) $\frac{3}{2} \sqrt{3fg}$
- D) None of these

7. In the figure shown, the speed of image with respect to mirror is :

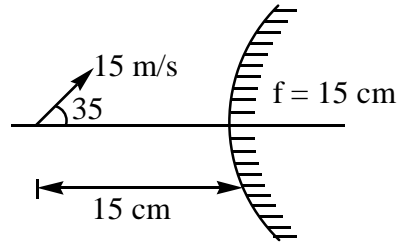

- A) 3 m/s B) 4.5 m/s C) 5.41 m/s D) 29.25 m/s

8. Equation of a reflecting surface is defined as $y = \frac{2L}{\pi} \sin \frac{\pi x}{L}$. A ray of light incident on this surface in first quadrant parallel to X axis becomes parallel to Y axis just after reflection. Find X co-ordinate point of incidence :

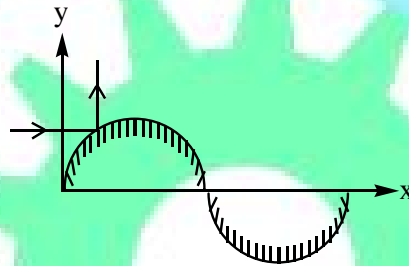

- A) $\frac{L}{6}$ B) $\frac{L}{3}$ C) $\frac{L}{4}$ D) $\frac{L}{8}$

9. M_1 and M_2 are two concave mirrors of the same focal length 10 cm. AB and CD are their principal axes respectively. An object is kept on the line AB at distance 15 cm from M_1 . The distance between the mirrors is 20 cm. Considering two successive reflections, first on M_1 and then on M_2 . The distance of final image from the line AB is :

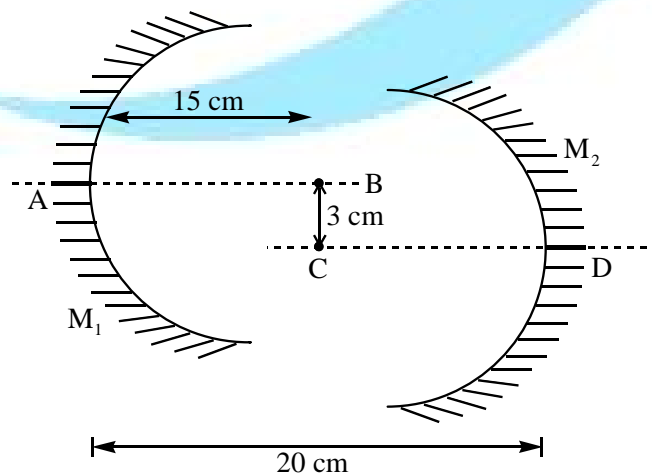

- A) 3 cm B) 1.5 cm C) 4.5 cm D) 1 cm

10. An object moves with a uniform velocity u_0 along the axis of a concave spherical mirror. Consider the instant shown in diagram, object is moving with $u_0 = 5 \text{ m/s}$ and $f = -10 \text{ cm}$. If object is at the centre of curvature at this instant then the magnitude of acceleration of image at this instant is $a \text{ m/s}^2$. Find a .

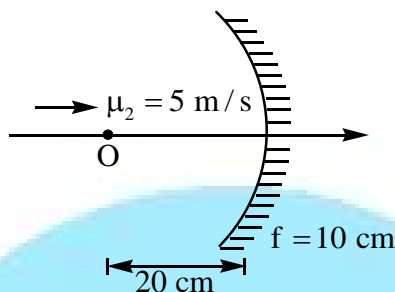

- A) 10 B) 5 C) 25 D) None of these
11. A large convex spherical mirror in an amusement park is facing a plane mirror 10 m away. A boy of height 1m standing midway between the two sees himself twice as tall as in plane mirror as in spherical one. In other words, the angle subtended at the observer by the image in plane mirror is twice the angle subtended by the image in the spherical mirror. What is the focal length of the convex mirror ?
- A) 5 m B) 2.5 m C) 1.8 m D) 3.6 m
12. The focal length of spherical mirror is given by $f = \frac{R}{2}$ when R is the radius of curvature of the mirror. For a given spherical mirror made of steel the focal length is $f = 24.0 \text{ cm}$. What is the new focal length if temperature is increased by 50°C ?
(Given $\alpha_{\text{steel}} = 12 \times 10^{-5} / \text{C}$)
- A) 24.0144 cm B) 20.0144 cm C) 28.0288 cm D) 24.144 cm

ONE OR MORE THAN ONE ANSWER CORRECT

13. Two plane mirrors at an angle such that a ray incident on a mirror undergoes a total deviation of 240° after two reflections.
- A) the angle between the mirror is 60°
 B) the number of images formed by this system will be 5, if an object is placed symmetrically between the mirrors
 C) the no. of images will be 5 if an object is kept unsymmetrically between the mirrors.
 D) a ray will retrace its path after 2 successive reflections, if the angle of incidence on one mirror is 60°

14. Velocity of object and concave mirror are shown in the diagram. At the given instant choose the **CORRECT** statement(s) :

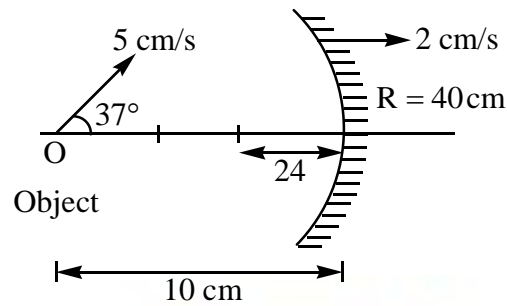

- A) Angle between velocity of image and velocity of object is 98°
 B) Velocity of image with respect to object is $\sqrt{109}$ cm/s
 C) Velocity of image with respect to object is $\sqrt{72}$ cm/s
 D) Velocity of image is in the direction of velocity of plane mirror
15. At time $t = 0$, two point objects A and B respectively are at pole and centre of curvature of a fixed concave mirror of focal length f : the velocity vectors of A and B are always $\vec{V}_A = u\hat{i}$ and $\vec{V}_B = -u\hat{i}$ respectively, where \hat{i} is unit vector along principal axis directed from pole towards focus and u is a positive constant :

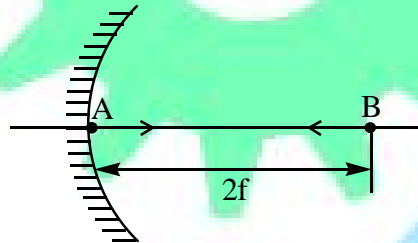

- A) The distance between images of A and B will be $4f$ at time $t = \frac{f}{2u}$
 B) Magnitude of relative velocity of image of A and image of B at $t = 0$ is $2u$
 C) Starting from $t = 0$ and before the particles come in contact distance between image A and B increases
 D) Starting from $t = 0$ and before the particles come in contact, distance between A and B first increases and then decreases

16. A car is moving with at a constant speed of 20 m/s on a straight road. Looking at the rear view mirror, the driver finds that the car following him is at a distance of 50 m and is approaching with a speed of 10 m/s. In order to keep track of the car in the rear, the driver begins to glance alternatively at the rear and side mirror of his car after every 2 s till the other car overtakes. If the two cars were maintaining their speeds, which of the following statement(s) is/are **CORRECT** ?

- A) The speed of the car in the rear is 30 m/s
- B) In the side mirror the car in the rear would appear to approach with a speed of 10 m/s to the driver of the leading car
- C) In the rear view mirror the speed of the approaching car would appear to decrease as the distance between the cars decreases
- D) In the side mirror, the speed of the approaching car would appear to increase as the distance between the cars decreases

COMPREHENSION-1

A point object starts moving in a circle of radius 1mm, with a constant angular acceleration of 1 rad/s^2 , in a plane perpendicular to the principal axis at a distance 20 cm from the pole of a concave mirror of focal length 25 cm. At time $t = 2\text{s}$ after the motion starts

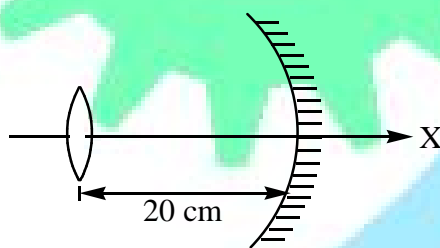

- 17. The ratio of acceleration of image and the object is :
 - A) 2
 - B) 4
 - C) 5
 - D) 25
- 18. Angle rotated by the image is :
 - A) 2 rad
 - B) 4 rad
 - C) 10 rad
 - D) 50 rad
- 19. Magnitude of relative velocity of object w.r.t. image :
 - A) 2 mms^{-1}
 - B) 5 mms^{-1}
 - C) 8 mms^{-1}
 - D) 10 mms^{-1}

COMPREHENSION-2

A particle is situated on the principal axis of a concave mirror at a distance d from the pole. Now a small angular displacement is given to the mirror in the anticlockwise direction about pole.

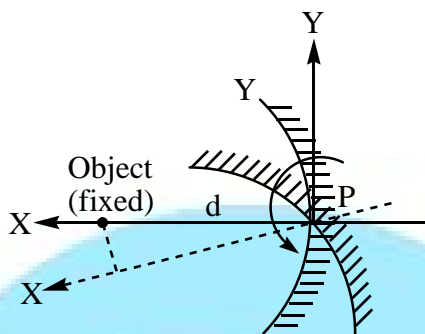

20. Graph between the “y-coordinate of image” and the angular displacement of the mirror :
(Considering new principal axis as x-axis.)

- A) Straight line of slope $\frac{fd^2}{(f+d)^2}$ B) Straight line of slope $\frac{f^2d}{(f-d)^2}$
 C) Straight line of slope $\frac{fd}{f-d}$ D) Straight line of slope $\frac{fd}{(f+d)^2}$

21. Two graphs have been plotted for the two different mirrors between d and $1/m$. Select the correct relation (where d is distance of object and m is magnification).

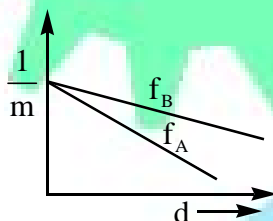

- A) $f_A > f_B$ B) $f_B > f_A$ C) $f_A = f_B$ D) Incomplete information

22. Find the Y coordinate of a point placed at centre of curvature if the mirror of focal length ‘ f ’ is rotated by an angle of $\frac{\pi}{50}$.

- A) $-\frac{\pi}{25}f$ B) $\frac{\pi}{25}f$ C) $\frac{3\pi}{50}f$ D) $-\frac{3\pi}{50}f$

COMPREHENSION-3

There is a simple and useful method for finding the focal length of a thin lens or a spherical mirror. We make two perpendicular lines as we draw on a graph. Suppose the object position is u and image positions is v . We mark u and v on horizontal and vertical lines and join these points by a straight line. Similarly we draw straight lines for other pairs of (u, v) . The common point of intersection of all these lines represents the focal length of the lens (or mirror) e.g. consider the table for (u, v) as shown below. This is a converging lens. The chart looks like this.

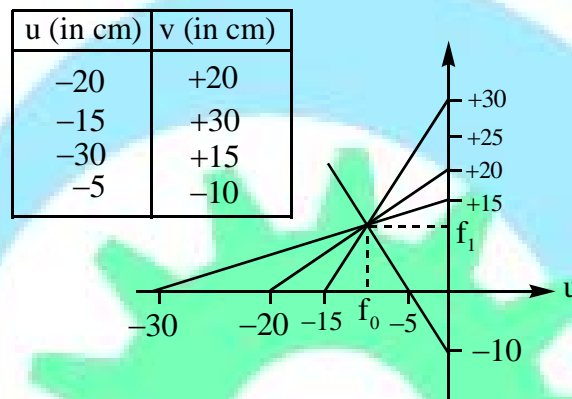

Here f_0 represents object focus
and f_1 represents image focus

Here focal length comes out to be 10 cm.

23. For a concave mirror graph for (Use Cartesian sign convention) :
- A) Real object and virtual image pair is a straight line with negative slope and positive intercept on y-axis
 - B) Real object and virtual image pair is a straight line with negative slope and negative intercept on y-axis
 - C) Real object and virtual image pair is a straight line with positive slope and positive intercept on y-axis
 - D) Real object and virtual image pair is a straight line with positive slope and negative intercept on y-axis
24. For two different pairs of (u, v) , the straight line are given by $2y = 5 + x$ and $3y = 10 + x$. This pair can be for (using Cartesian sign convention) :
- A) Converging lens
 - B) Diverging lens
 - C) Concave mirror
 - D) Convex mirror





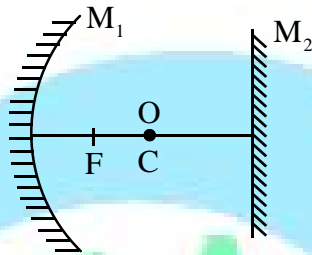

MATCHING

25. An object is placed at centre of curvature C of the spherical mirror. Column – II corresponds to velocity of image (I_1) in mirror m_1 with respect to image (I_2) in mirror M_2 . Column – I corresponds to motion of object and mirrors M_1 and M_2 .

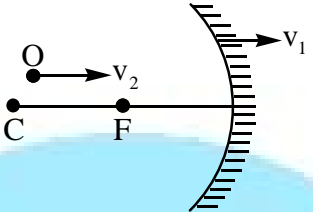

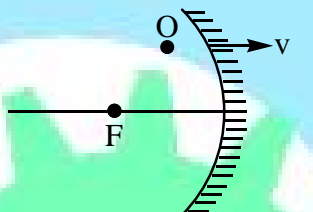
	Column – I		Column – II
(a)	$O \rightarrow V$ towards right $M_1 \rightarrow$ at rest, $M_2 \rightarrow$ at rest	(p)	Zero
(b)	$O \rightarrow \frac{V}{2}$ towards right $M_1 \rightarrow V$ towards right, $M_2 \rightarrow$ at rest	(q)	V
(c)	$O \rightarrow$ at rest $M_1 \rightarrow V$ towards right, $M_2 \rightarrow \frac{V}{2}$ towards left	(r)	$2V$
(d)	$O \rightarrow V$ towards right $M_1 \rightarrow \frac{V}{2}$ towards right, $M_2 \rightarrow$ at rest	(s)	$3V$
		(t)	$V/2$

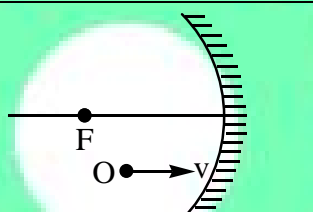
26. In column – I possible instantaneous velocity vector of the image with respect to ground are shown. These are corresponding to the situations shown in column – II. Match column-I with the situations shown in column – II.

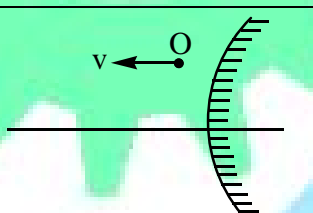
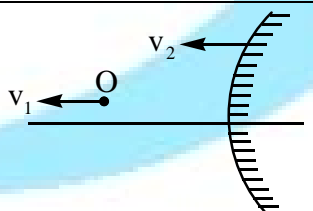
	Column – I		Column – II
(a)		(p)	
(b)		(q)	
(c)		(r)	
(d)		(s)	
		(t)	

INTEGER

27. A kid of height 1.1 ft is sleeping straight between focus and centre of curvature along the principal axis of a concave mirror of small aperture. His head is towards the mirror and is 0.5 ft from the focus of the mirror. Now a plane mirror is placed so that the image formed by it due to reflected light from concave mirror looks like a person of height 5.5 ft. Find the focal length (in feet) of the concave mirror.
28. A point object is placed at the centre of curvature of a concave mirror (taken as origin). A plane mirror is also placed at a distance of 10 cm from the object as shown. Consider two reflection first at plane mirror and then at concave mirror (x_0, y_0) . Find $\frac{\pi x_0}{y_0}$ the coordinates of the image thus formed are.

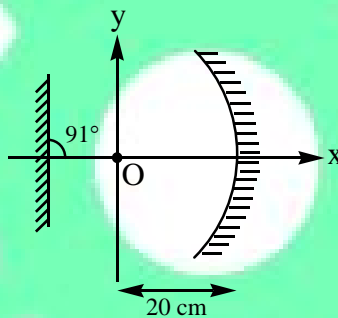

29. Find the co-ordinates of image of point object P formed after two successive reflection in situation as shown in figure considering first reflection at concave mirror and then at convex.

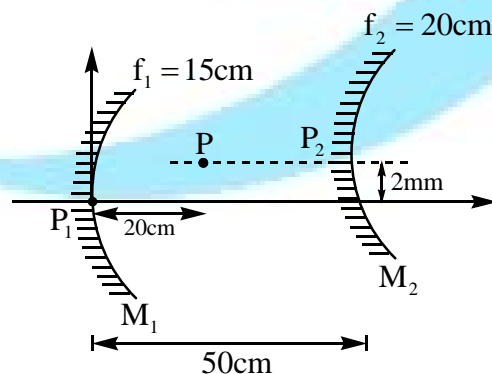

30. The principal axis of a spherical mirror is shown by dotted line. O is the point object whose real image is I. Find the distance of the pole and centre of curvature of the mirror from object measured along principal axis by drawing ray diagram.

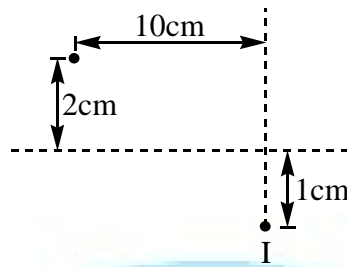

31. Consider a concave mirror kept at origin with focal length 40 cm. Parallel rays which subtend an angle $\theta = \frac{1}{40}$ radian are incident on it. A convex mirror is kept at a distance 25 cm from the first mirror as shown. Find the y-coordinate of the image (in cm) formed by the system of mirrors after two reflections.

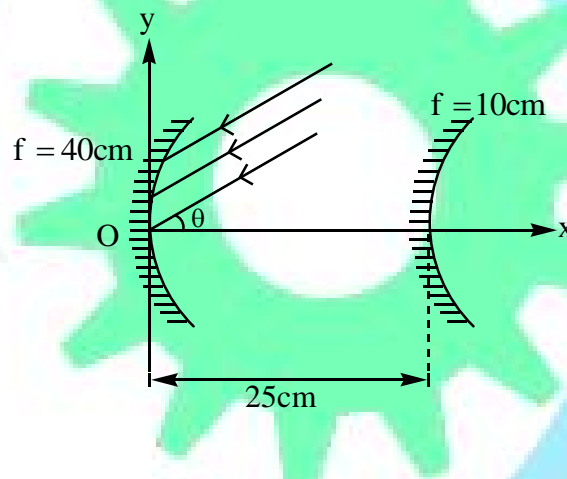

32. A parabolic reflecting surface given by $x = \frac{y^2}{2}$, is placed at origin, as shown. An incident ray moving along $y = 1$ is incident on it. The ray gets reflected by the surface twice. The deviation suffered by the ray is $\frac{\pi}{n}$ radian. Find n.

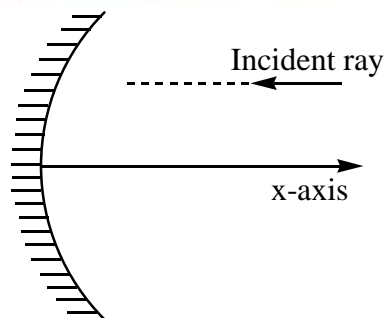

33. A bright point S is on the principal optical axis of a concave mirror of radius $R = 40$ cm at $d = 30$ cm from its pole. At what distance (in cm) in front of the concave mirror should a plane mirror be placed so that after two reflections, the rays converge back at point S.
34. A concave mirror forms a real image on a screen of thrice the linear dimension's of the real object. Object and screen are moved until the image is twice the size of the object. If the shift of the object is 6 cm. Find focal length f (in cm).

SUBJECTIVE

35. In the diagram xz plane is a mirror with reflecting surface pointing in $+y$ direction. A light ray given by $-\hat{i} - \hat{j} - \hat{k}$ is incident on mirror.
- (1) what is reflected light ray vector.
- (2) Now mirror is rotated by 45° about x axis, new reflected ray vector?

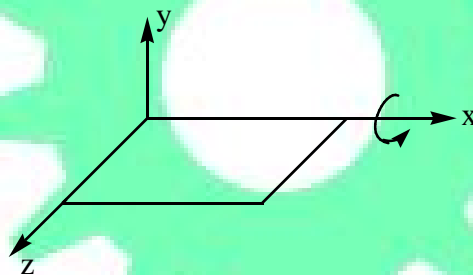

36. A plane mirror 50 cm long, is hung parallel to a vertical wall of a room, with its lower edge 50 cm above the ground. A man stands in front of the mirror at a distance 2 m away from the mirror. If his eyes are at a height 1.8 m above the ground, find the length of the floor between him & the mirror, visible to him reflected from the mirror.

37. A light ray I is incident on a plane mirror M. The mirror is rotated in the direction as shown in the figure by an arrow at frequency $\frac{9}{\pi}$ rev/sec. The light reflected by the mirror is received on the wall W at a distance 10 m from the axis of rotation. When the angle of incidence becomes 37° find the speed of the spot (a point) on the wall?

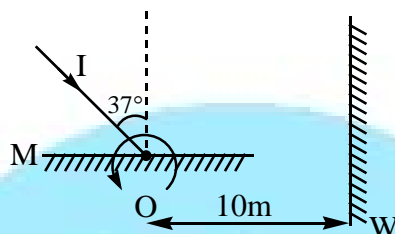

38. A cylindrical container filled with mercury uniformly rotates with angular speed ω about its vertical axis of symmetry. Astronomers use the surface of mercury in this experiment as a mirror. At what position should a photo film be put to get a clear picture of a distant star?
39. A concave mirror of radius of curvature 40 cm can be rotated about an axis \perp to the plane of the paper passing through point A as shown. A ray of light parallel to the principal axis is passing through the pole after reflection. The mirror is rotated about the axis by an angle of $5x^\circ$ so that the ray of light now passes through C (the centre of curvature before rotation). Find x in degrees

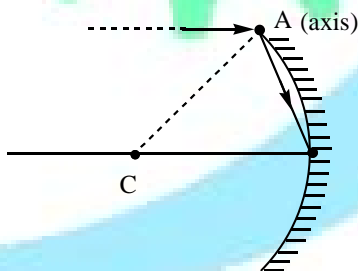

40. A concave mirror of focal length 20 cm is cut into two parts from the middle and the two parts are moved perpendicularly by a distance 1 cm from the previous principal axis AB. Find the distance between the images formed by the two parts?

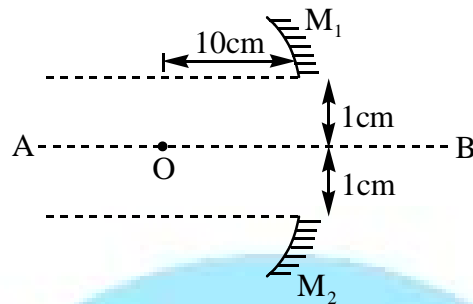

41. Two concave mirrors each of radius of curvature 40 cm are placed such that their principal axes are parallel to each other & at a distance of 1 cm to each other. Both the mirrors are at a distance of 100 cm to each other. Consider first reflection at M₁ and then at M₂, find the coordinates of the image thus formed. Take location of object as the origin.

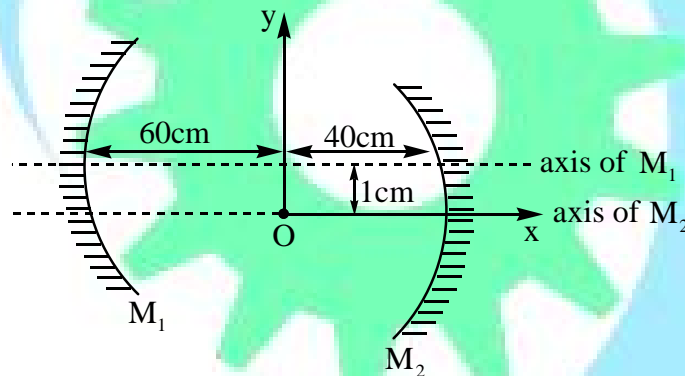

42. A silvered ball of radius $r = 5.0$ cm is so suspended that its centre is $h = 1.0$ m above the floor and $s_0 = 2.0$ m horizontally away from a person of height $h_0 = 2.0$ m. There is also a large plane mirror, which stands vertically at some distance from the person. If the person sees his image in the ball as small as he sees his image in the plane mirror, how far is the plane mirror from the person ?

PART-A LEVEL-I (THEORY)

1	2	3	4	5	6	7	8	9	10
C	B	B	A	D	A	B	B	C	B
11	12	13	14	15	16	17	18	19	20
D	B	A	C	AD	AB	B	BC	ACD	AC
21	22	23	24	25	26	27	28	29	30
AC	CD	BC	C	C	B	AC	AC	a-pqr, b-r, c-q, d-pqr	a-r, b-p, c-q, d-s
31	32	33	34						
a-qt, b-st, c-pr, d-qt	a-qr, b-pr, c-ps, d-ps	1	16 mm ³						

PART-B LEVEL-II (APPLICATIONS)

1	2	3	4	5	6	7	8	9	10
B	B	A	D	C	B	C	B	B	D
11	12	13	14	15	16	17	18	19	20
B	D	ABCD	AB	ABC	AD	C	A	C	C
21	22	23	24	25	26	27	28	29	30
B	A	C	D	a-p, b-r, c-s, d-q	a-pq, b-rt, c-pt, d-pst	2	180	3cm, -14mm	20, 20/3
31	32	33	34	35	36	37	38	39	40
2	1	45	36	-	1.23 m	1000m/s	$\frac{g}{2\omega^2}$	$x = 6^0$	2 cm
41	42								
(12, -0.6)	-								

35. i) $\frac{-1}{\sqrt{3}}(\hat{i} - \hat{j} + \hat{k})$ ii) $\frac{-1}{\sqrt{3}}(-\hat{i} + \hat{j} + \hat{k})$

42. $\approx \frac{4s_0^2 + h_0^2}{4r} = 100 \text{ m}$